

Example:
Visual display of level monitoring system NRR 2-40

Control Terminal and Display Unit

Type URB 1

CANopen

System Description

The URB 1 is a user-friendly control terminal and display unit for use with GESTRA CAN bus systems. With the URB 1 all standard functions of the CAN bus systems can be easily called up and adjusted. The URB 1 uses the CANopen protocol.

Furthermore, the URB 1 makes the parameterization of the controller very convenient: The switchpoints, the response sensitivity and the proportional band can be adjusted by means of the keypad regardless of the actual values (level, conductivity). The energizing and deenergizing times of the relays can be customized for the switchpoints.

The URB 1 features a continuous display and therefore meets the requirements of TRD 401 / EN 12952 and EN 12953 for a second water level indicator. The equipment has also a temperature-compensated conductivity indication as required by VdTÜV – Bulletin WÜ 100 (Water Level 100).

The equipment indicates also malfunctions such as faulty electrode, excessively high temperature in a sensor, ambient temperature above max. limit, faulty communication etc.

The following tables specify the GESTRA equipment that can be displayed by the URB 1:

Standard display information	Level					Conductivity
	NRS 1-40	NRS 1-41	NRS 1-42	NRS 2-40	NRR 2-40	LRR 1-40
Actual value (bar chart)				●	●	●
Actual value (numerical value)				●	●	●
Switchpoint (symbol)			●	●	●	●
High level alarm (electrode HW)			●	●	●	●
Low level alarm (electrode LW)			●	●	●	●
Manual/automatic operation				●	●	●
Stand-by mode						●
Unit [µS/cm] or [ppm]						●
Low level limit	●					
High level limit		●				
Alarm (warning triangle) ⚠	●	●				

Further display information	Level					Conductivity
	NRS 1-40	NRS 1-41	NRS 1-42	NRS 2-40	NRR 2-40	LRR 1-40
Actual value (continuous)				●	●	●
Switchpoints			●	●	●	●
Setpoint					●	●
Deviation					●	●
Valve position					●	●
Intermittent blowdown						●
Intermittent blowdown interval						●
Purging pulse 24 h						●
Current CAN bus addresses	●	●	●	●	●	●

Important Note

Note that screened multi-core twisted-pair control cable is required for the BUS line, e. g. UNITRONIC® BUS CAN 2 x 2 x ... mm² oder RE-2YCYV-fl 2 x 2 x ... mm².

The baud rate (data transfer rate) dictates the cable length between the bus nodes and the total power consumption of the sensor dictates the conductor size.

S 8	S 9	S 10	Baud rate	Cable length	Number of pairs and conductor size [mm ²]
OFF	ON	OFF	250 kBit/s	125 m	2 x 2 x 0.34
Factory setting					
ON	ON	OFF	125 kBit/s	250 m	2 x 2 x 0.5
OFF	OFF	ON	100 kBit/s	335 m	2 x 2 x 0.75
ON	OFF	ON	50 kBit/s	500 m	on request, dependent on bus configuration
OFF	ON	ON	20 kBit/s	1000 m	
ON	ON	ON	10 kBit/s	1000 m	

The baud rate is set via a code switch. Reduce baud rate if cable is longer than specified in the table. Make sure that all bus nodes have the same settings. To protect the switching contacts fuse circuit with 2.5 A (anti-surge fuse) or according to TRD regulations (1.0 A for 72 hrs operation).

Note: If the cable is longer than 125 m (max. 1000 m!) the baud rate must be changed.

Control Terminal and Display Unit Type URB 1

CANopen

Function

The URB 1 communicates with other GESTRA systems via a CAN bus to DIN ISO 11898 using CANopen protocol.

Design

URB 1

Case according to DIN ISO 43700 for panel mounting.
The terminals are accessible from the back.
Installation in panel cut-out by means of fixing clips supplied with the equipment.
Dimensions of panel cut-out:
92±0.8 mm x 92±0.8 mm.

CAN Bus

All level and temperature switches, controllers and electrodes are interconnected by means of a CAN bus. The data exchange is effected by means of a CAN bus according to DIN ISO 11898 using the CANopen protocol. Every item of equipment features an electronic address (Node ID). The four-core bus cable serves as power supply and data highway for high-speed data exchange.

URB 1 is configured at our works and ready for service with other GESTRA components.

URB 1 can be used straight away without having to set the Node ID.

Technical Data

Type approval no.

TÜV · WÜL · 02-007
BAF-MUC 0205 103881 003

Data exchange

CAN bus to DIN ISO 11898
CANopen protocol

Indicators and adjustors

1 illuminated display,
resolution: 128 x 64 pixels
5 push buttons

Supply voltage

18 V – 36 V DC

Protection

Front panel: IP 54 to DIN EN 60529
Back: IP 00 to DIN EN 60529

Admissible ambient temperature

0 °C – 55 °C

Case material

Front face: Aluminium with polyester membrane
Back: Noryl GFN 2 SE 1, glass-fibre reinforced

Weight

Approx. 0.3 kg

Order and Enquiry Specification

GESTRA Control terminal and display unit type URB 1 CANopen.

Supply in accordance with our general terms of business.

Dimensions

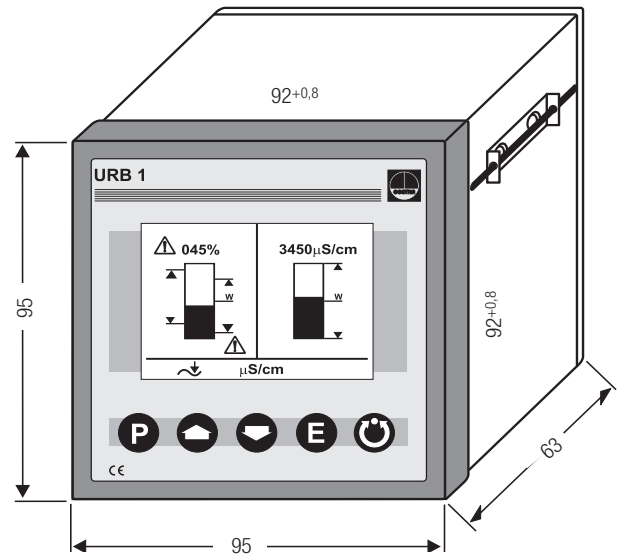

Wiring Diagram

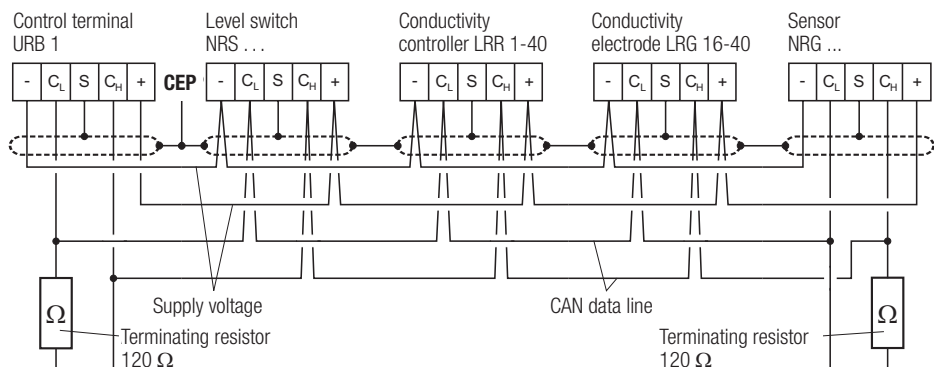
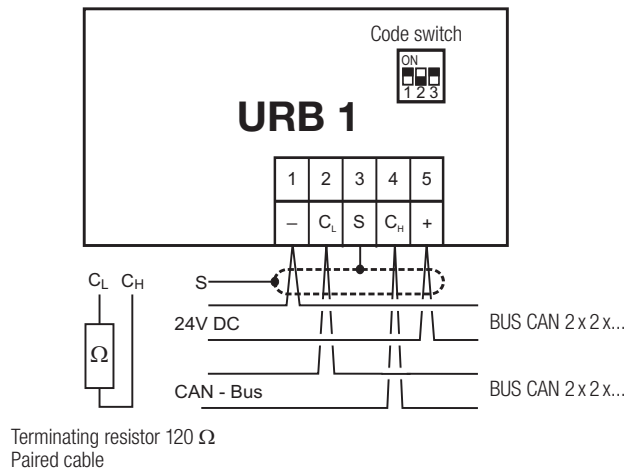

GESTRA AG

Münchener Straße 77, 28215 Bremen, Germany
Telefon +49 421 3503-0, Telefax +49 421 3503-393
E-mail info@de.gestra.com, Web www.gestra.de

